

LEYMAN LIFT GATES®

Model LHLP
LHLP 4500
LHLP 5500

HIDE-A-WAY®
Large Aluminum
Level Ride Platform



Featuring



LEYMAN  LIFT GATES®

www.anjerinc.com
800-326-5373
sales@anjerinc.com

Model LHLP

Standard Features

- Pressure compensated flow control
- Two toggle switch operation
- 12 volt D.C. power supply
- Chrome plated pins
- Low P.S.I. due to larger piston surface area
- Automatic mechanical tilt
- Power down on demand
- Aluminum bi-fold platform
- Level ride platform
- Maintenance Minder²® Power Unit
- Spring assisted closing
- Greaseable bushings
- Power unit enclosure holds pump and motor
- Thermal switch to cut off motor at high temperature
- Two cylinders
- Two foot operated cart stops
- Available with extension or threshold insert tube for 96"/102" wide vehicle

Optional Features

- Emergency hand pump
- Safety cut off switch
- Quick mount system
- Hand held remote control
- ICC Bumper DOT approved
- Heavy duty steps
- Rubber dock bumpers
- Circuit breaker for pump motor
- Battery box

Standard Specifications

Capacity: 4500 and 5500 lbs.

Weight: 1000 - 1150 lbs. (approx.)

Platform Size: 86" wide x 60" deep

Floor Heights: 47" - 60"

HIDE-A-WAY®

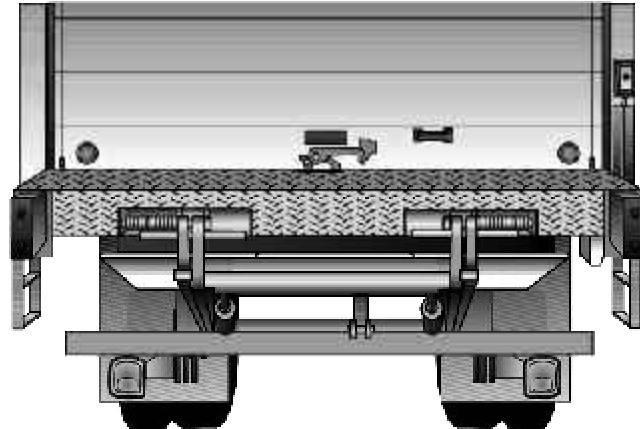

Over the Road Position

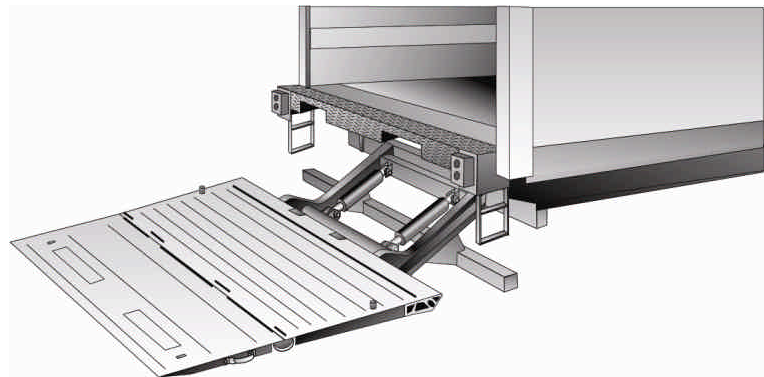

Extension Plate Added to Rear of Vehicle

LEYMAN  **LIFT GATES®**